

# Clamping elements for workbenches

Clamp on workbenches securely and variably



Simply better.



## Clamping element with variable throat depth TWV

TWV...-2K



TWV...K

Order-No.	Ø	Clamping height max.	Throat depth	Rail	kg	qty.	V3
	mm	mm	mm	mm			
TWV16-20-15-2K	16	200	30-150	22 x 8.5	1.20	1	
TWV16-20-15K	16	200	30-150	22 x 8.5	1.04	1	
TWV16-20-15H	16	200	60-150	22 x 8.5	1.21	1	

## Clamping element with fixed throat depth TW

TW...H



Order-No.	Ø	Clamping height max.	Throat depth	Rail	kg	qty.	V3
	mm	mm	mm	mm			
TW16-20-10-2K	16	200	100	22 x 8.5	0.93	1	
TW16-20-10K	16	200	100	22 x 8.5	0.86	1	
TW16-20-10H	16	200	100	22 x 8.5	1.01	1	

TW...-2K



TW...K

TW...H



- Precise, individual clamping
- Tempered profile and sliding arm for sprung and elastic clamping
- Infinitely adjustable throat depth (TWV)

Various design versions:

- High quality 2-component plastic handle and tommy bar with rounded ends – each with smooth-running trapezoidal threaded spindle and tool-free pressure plate replacement
- Lever handle with an indexing mechanism for controlled, fast and vibration-proof

3D-CAD data for download at [www.bessey.de](http://www.bessey.de)

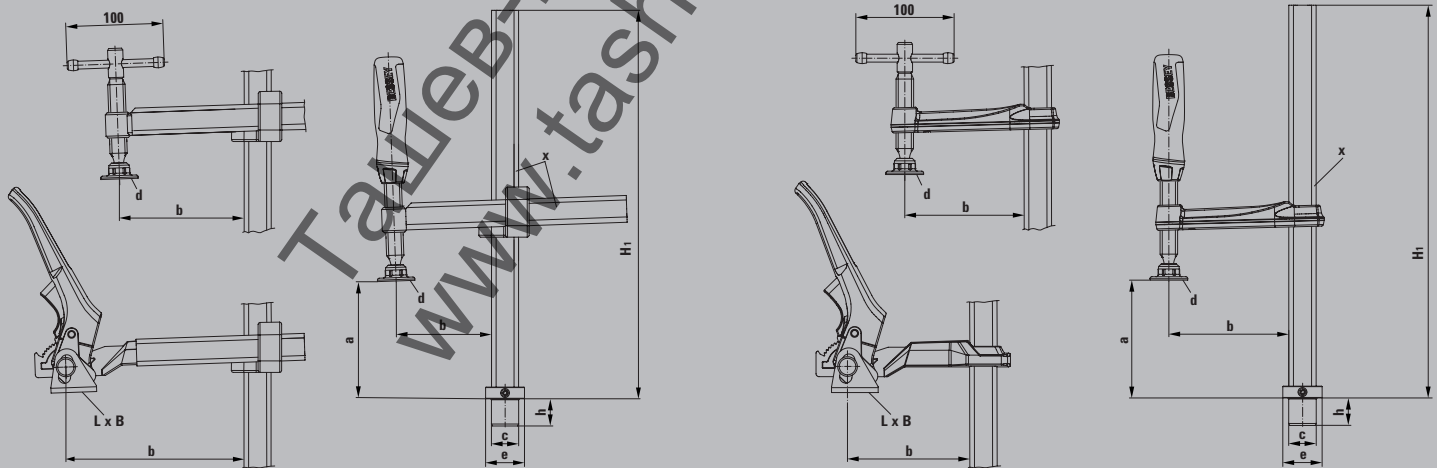

Table of dimensions

	Bolt Ø	Bolt height	Clamping height "a"	Throat depth "b"	Height of base "H1"	Pressure plate dimensions		Foot "F"		Rail profile "x"
	"c"	"h"				"L x B"	Ø "d"	Foot Ø "e"	Foot height	
	mm	mm				mm	mm	mm	mm	
TWV16-20-15-2K	16	20,5	200	30-150	265	–	32	30	10	22 x 8.5
TWV16-20-15K	16	20,5	200	30-150	265	–	32	30	10	22 x 8.5
TWV16-20-15H	16	20,5	200	60-150	265	41 x 26	–	30	10	22 x 8.5
TW16-20-10-2K	16	20,5	200	100	265	–	32	30	10	22 x 8.5
TW16-20-10K	16	20,5	200	100	265	–	32	30	10	22 x 8.5
TW16-20-10H	16	20,5	200	100	265	41 x 26	–	30	10	22 x 8.5

# Clamping elements for workbenches

Clamp on workbenches securely and variably



Simply better.



## Easily and quickly to use

BESSEY clamping elements of the TWV16 and TW16 series can be used with just a few turns on all standard workbenches:

- due to the connection of the **TW16AW workbench adapter** – available in 5 sizes suitable for 19 mm, 20 mm, 22 mm, 25.4 mm and 30 mm hole diameter
- due to replaceable bolts on the adapter for the use of further hole systems

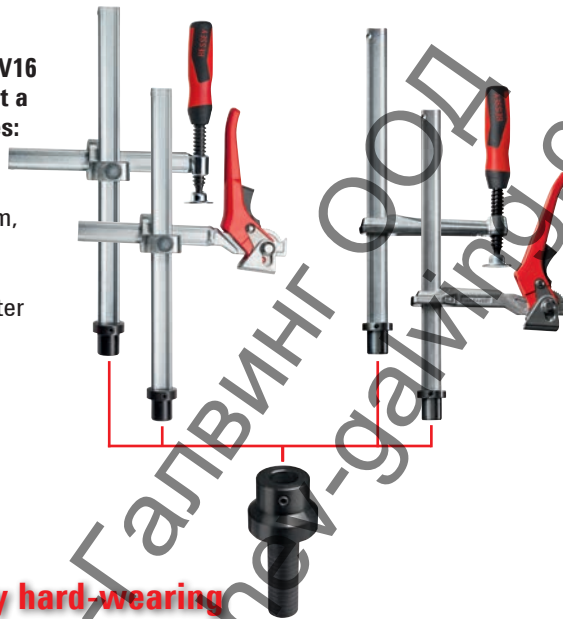

## Precise and safe

BESSEY always offers the right clamping element for different requirements:

- due to **2 throat depth variants**: either with infinitely adjustable (TWV) or fixed throat depth (TW)
- due to **3 handle variations**: the 2-component plastic handle and tommy bar – each with smooth-running trapezoidal threaded spindle and tool-free pressure plate replacement – and lever handle with an indexing mechanism for controlled, fast and vibration-free clamping

## Robust and highly hard-wearing

The tried-and-tested BESSEY all-steel clamp solutions were the inspiration for the development of the clamping elements and guarantee a form-stable and torsion-free tool:

- due to the unique **BESSEY steel quality**, which is available in the optimized profile shape as well as the easy-going spindle
- due to the particularly **hard-wearing steel cams at the lever handle**

Now adapter available in 5 versions

Workbench adapter TW16AW

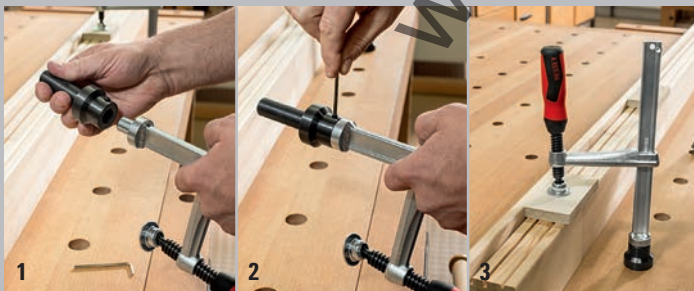

Order-No.	Ø	Suitable for		kg	qty.	V3
		mm	"			
TW16AW19	16	19	3/4	0.33	1	
TW16AW20	16	20	13/16	0.35	1	
TW16AW22	16	22	7/8	0.35	1	
TW16AW25	16	25.4	1	0.44	1	
TW16AW30	16	30	1 3/16	0.53	1	

For further information  
www.bessey.de



Your dealer:

BESSEY Tool GmbH & Co. KG ■ Mühlwiesenstr. 40  
74321 Bietigheim-Bissingen, Germany  
Fon +49 7142 401-0 ■ Fax +49 7142 401-452  
E-Mail: info@bessey.de ■ www.bessey.de